

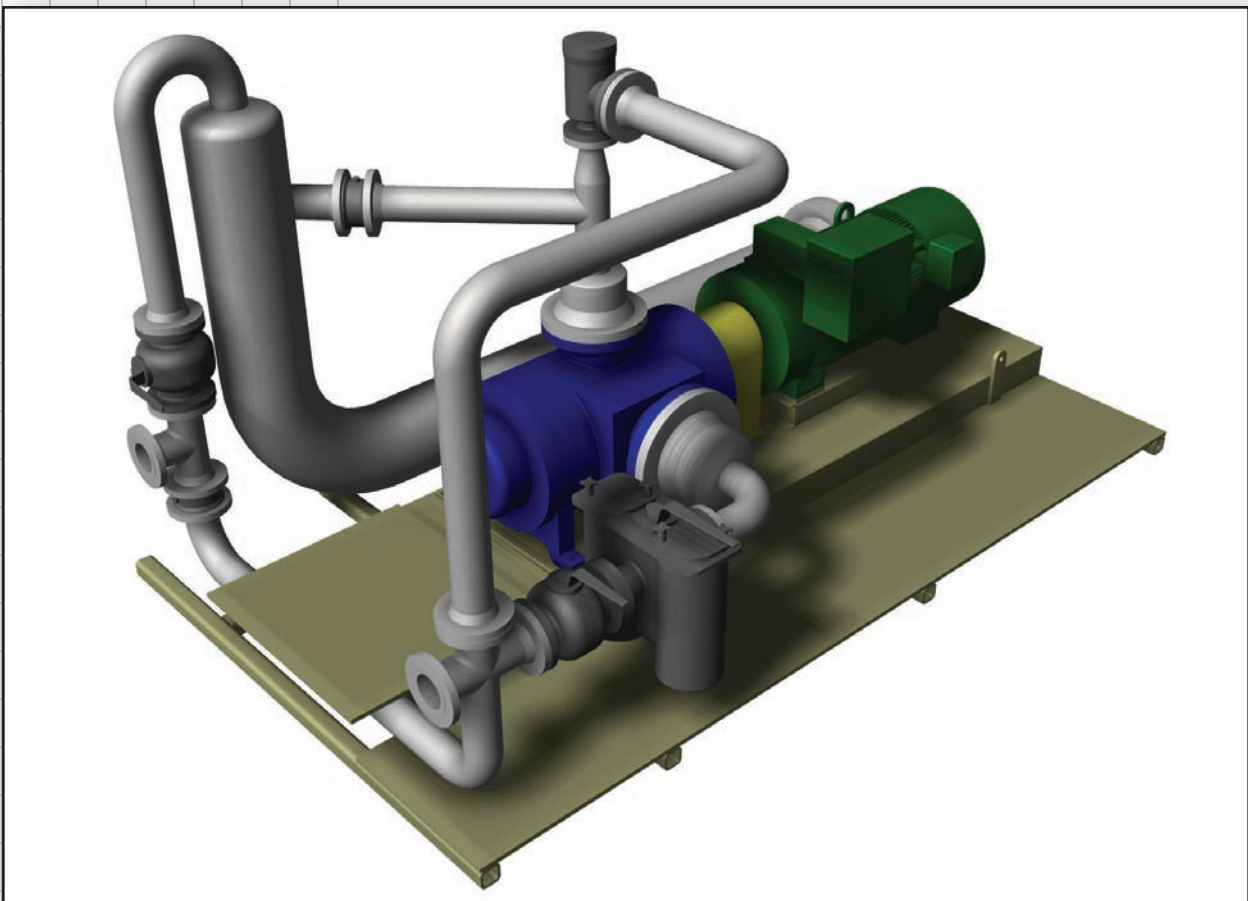

# **Leistritz**

**PROVEN AND VERIFIED TO  
INCREASE PRODUCTION**

**MPS-186 Multiphase  
Production System**



- Pay-off in a matter of months.
- Eliminates conventional separation systems with compressor and separate flowlines.
- Accelerates production by lowering back pressure on the wellhead.
- Dependable technology that simplifies your production facilities.
- Delays abandonment and increases total hydrocarbon recovery.

**Availability:** Complete standardized package available in 16 to 20 weeks, subject to prior sale.

## Basic P&ID

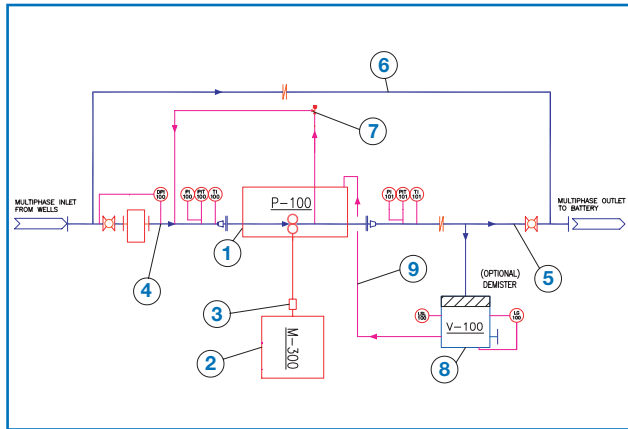

Flow and Power vs Pressure  
L4MK 186 (@100 cSt, 1750 RPM)

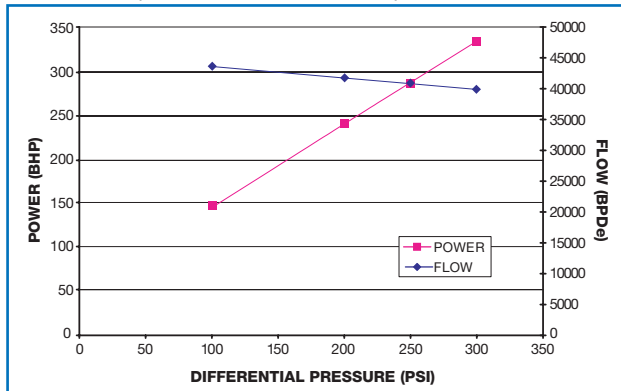

## Overall Dimensions

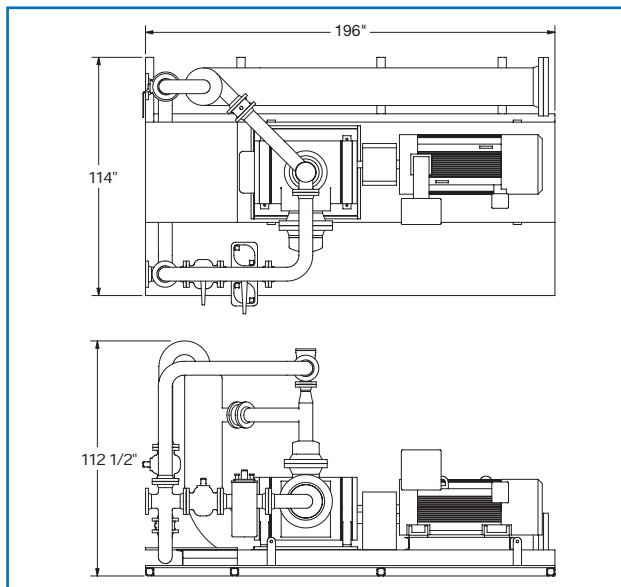

## 1. Multiphase Pump

Leistriz twin screw multiphase pump with replaceable liner, cast steel or ductile iron casing, and integral steel rotors. Rotors are gas nitrided for increased wear resistance. Single mechanical seals with a throat bushing, API plan 32 flush.

## 2. Driver

Both electric motor and engine drivers are available. Electric motor is normally inverter duty type, enabling the pump to maintain a constant inlet pressure independent of well pressure (VFD required.)

## 3. Coupling

Spacer coupling for easy service and maintenance. Allows access to seals and bearings on pump drive end.

## 4 and 5. Suction and Discharge Piping Headers

Per ASME B31.3 with check valves, isolation valves and instrumentation as required. Piping is Sch. 40 rated for 300 lbs.

## 6. By-pass Piping Header

By-pass header allows the wells to flow around the pump in the event the pump shuts down.

## 7. Pressure Relief Valve

Pump available with an integral relief valve. Optionally, a separate PSV with piping back to suction header is available.

## 8. Liquid Recovery Trap

The liquid trap collects liquids from the flow discharged by the multiphase pump. The trap is approximately 80% efficient without a demister, and up to 99% efficient with a demister, which is recommended for wet gas applications. The trap has no moving parts and is sized to store sufficient liquid to maintain pump prime during the longest anticipated gas slug interval. Constructed of standard pipe material, the trap has a drain for solids, and can also accommodate liquid injection from a secondary source.

## 9. Recycle Line

The recycle line draws liquid from the Liquid Recovery (Item 8) and injects the liquid into the seal chambers. This liquid flushes the seal faces as well as the pumping chambers.

# Leistriz

Leistriz Corporation, 165 Chestnut Street, Allendale, NJ 07401  
(201) 934-8262 • Fax: (201)934-8266 • [www.leistrizcorp.com/pumps](http://www.leistrizcorp.com/pumps)