



Leistritz

CANTILEVERED TELESCOPIC HOLELESS HYDRAULIC ELEVATOR PACKAGES

The Cantilevered telescopic holeless elevator design from Leistritz eliminates the uncertainty of an in ground cylinder and inconvenience of longer installation times and expense caused by drilling holes. The telescopic hydraulic cylinder is completely above ground, where it can be easily inspected and maintained, and where it remains safe from oil leaks and corrosion.

Each Leistritz Holeless Hydraulic Elevator Package contains:



- Hydraulic cylinders with honed pistons;
- Submersible power unit incorporating a low pulsation screw pump, oversized submersible motor, and a muffler that eliminates the pulsation of pressurized oil for a smoother and quieter ride;
- Car sling package with guide rails, brackets, platform, toeguard, roller guides, buffers, limit switches, cam, and all necessary hardware;
- Manual of shop and field installation drawings.

Each component is manufactured to exacting quality standards, and rigorously inspected at Leistritz before shipment.

For smaller and medium sized installations this combination of a cantilevered sling with a telescopic cylinder often offers the best elevator application. Standard cantilevered configurations are described on the following pages.

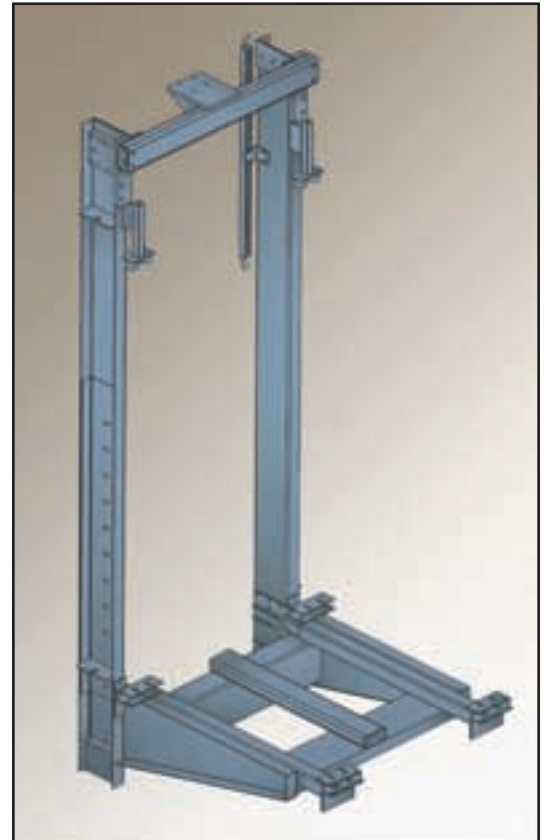

CANTILEVERED DIRECT/TELESCOPIC PASSENGER

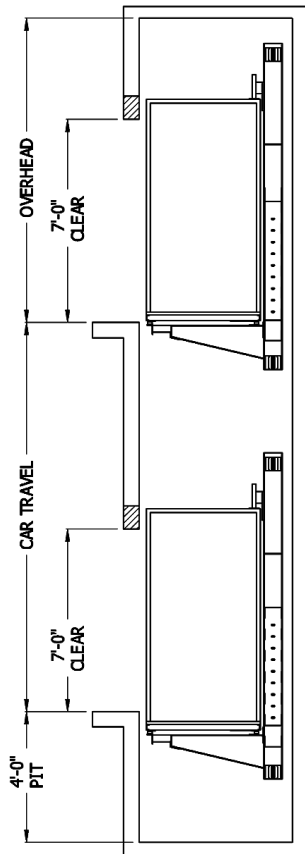
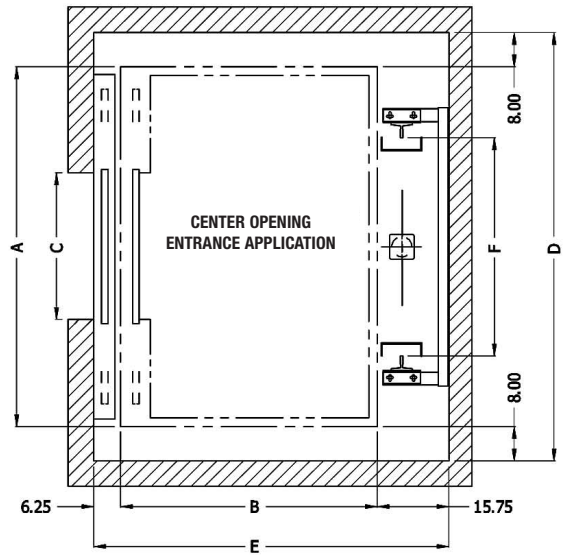
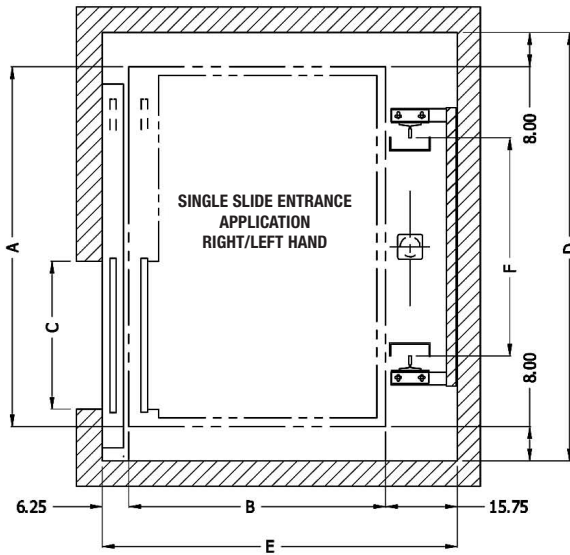

SPECIFICATIONS: CANTILEVERED DIRECT/TELESCOPIC PASSENGER

Type	Cantilevered Direct/Telescopic Front Opening Only			
Service	Passenger			
Speed	80 FPM, 100 FPM, 125 FPM, 150 FPM			
Capacity	2000 lb	2500 lb	3000 lb	3500 lb
Clear Car Size				
W x D	5'-8" x 4'-3"	6'-8" x 4'-3"	6'-8" x 4'-9"	6'-8" x 5'-5"
A	6'-0"	7'-0"	7'-0"	7'-0"
B	5'-0"	5'-0"	5'-6"	6'-2"
C	3'-0"	3'-6"	3'-6"	3'-6"
D	7'-4"	8'-4"	8'-4"	8'-4"
E	6'-10"	6'-10"	7'-4"	8'-0"
F	4'-3 1/8"	4'-3 1/8"	4'-3 1/8"	4'-3 1/8"
Pit	4'-0" Standard			
Overhead	Travel dependent, consult Leistriz engineering with questions.			
Machine Room	7'-0" x 5'-0" x 7'-6"			
	Machine room may vary. Consult Leistriz engineering with questions.			
Entrance Types	Single Slide (Left or Right) Center Opening (Not available for 2000 lb Capacity)			
Travel	Up to 30 ft., consult Leistriz engineering for your application.			

Leistriz

Contact us for information about our custom Cantilevered Telescopic systems, or for complete descriptions of other Leistriz systems. (201) 934-8262 • www.leistrizcorp.com

CANTILEVERED DIRECT/TELESCOPIC PASSENGER

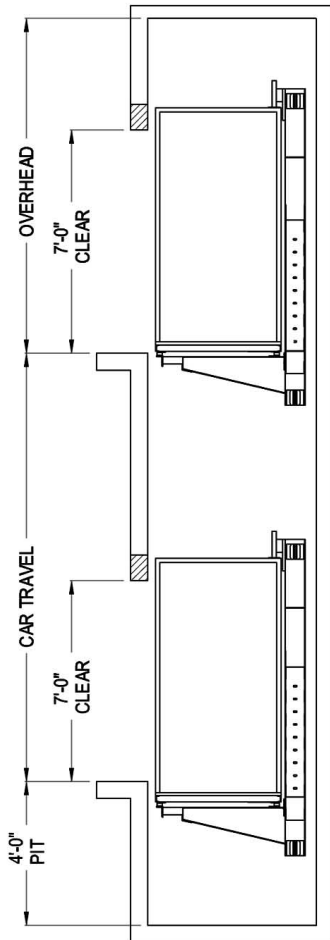
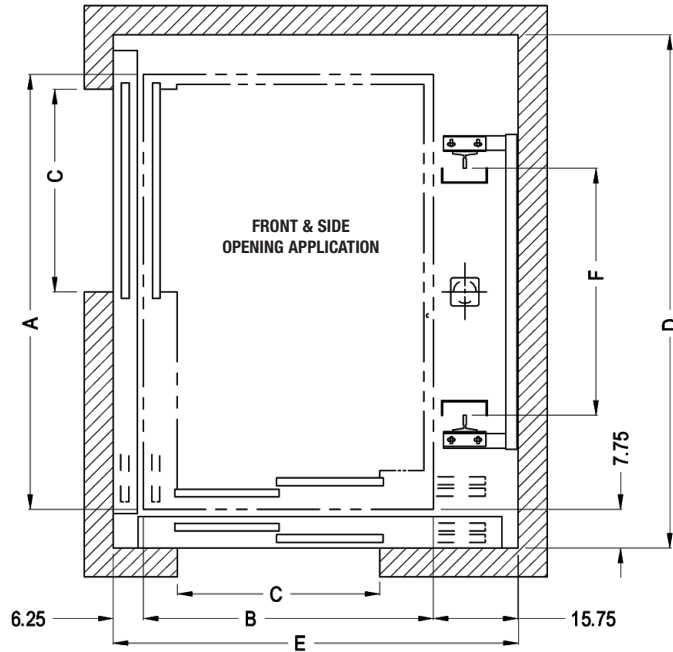

SPECIFICATIONS: CANTILEVERED DIRECT/TELESCOPIC PASSENGER

Type	Cantilevered Direct/Telescopic Front & Side Opening			
Service	Passenger			
Speed	80 FPM, 100 FPM, 125 FPM, 150 FPM			
Capacity	2000 lb	2500 lb	3000 lb	3500 lb
Clear Car Size	W x D			
	A	6'-6"	7'-6"	7'-6"
B	5'-0"	5'-0"	5'-6"	6'-2"
C	3'-0"	3'-6"	3'-6"	3'-6"
D	7'-8"	8'-8"	8'-8"	8'-8"
E	6'-10"	6'-10"	7'-4"	8'-0"
F	4'-3 1/8"	4'-3 1/8"	4'-3 1/8"	4'-3 1/8"
Pit	4'-0" Standard			
Overhead	Travel dependent, consult Leistriz engineering with questions.			
Machine Room	7'-0" x 5'-0" x 7'-6" Machine room may vary. Consult Leistriz engineering with questions.			
Entrance Types	Right/Left Hand			
Travel	Up to 30 ft., consult Leistriz engineering for your application.			



Contact us for information about our custom Cantilevered Telescopic systems, or for complete descriptions of other Leistriz systems. (201) 934-8262 • www.leistrizcorp.com



Leistritz

*Leistritz Corporation, 165 Chestnut Street, Allendale, NJ 07401
(201) 934-8262 • Fax: (201)934-8266 • www.leistritzcorp.com*

© 2004

Printed in U.S.A.