



Leistriz

TW INLIGHT™ HOLELESS HYDRAULIC ELEVATOR PACKAGES FOR 2-LANDING INSTALLATIONS

The Twinlight holeless elevator design from Leistriz eliminates the dirt, noise, installation time and expense caused by drilling holes for in-ground hydraulic cylinders. Twinlight, hydraulic cylinders bolt to the surface of the pit floor, where they can be easily inspected and maintained, and where they remain safe from rust and corrosion.

Each Leistriz Holeless Hydraulic Elevator Package contains:



- hydraulic cylinders with honed pistons;
- submersible power unit incorporating a low pulsation screw pump, oversized submersible motor, and a muffler that eliminates the pulse of pressurized oil for a smoother ride, and greater reliability;
- car sling package with guide rails, brackets, platform, toeguard, guide shoes, limit switches, cam, and all necessary hardware;
- manual of shop drawings.

Each component is manufactured to exacting quality standards, and rigorously tested at Leistriz before shipment.

Four Twinlight configurations are described on the reverse. All equipment is shipped from stock within three weeks following approval of shop drawings. Complete information and specifications are available by contacting Leistriz.

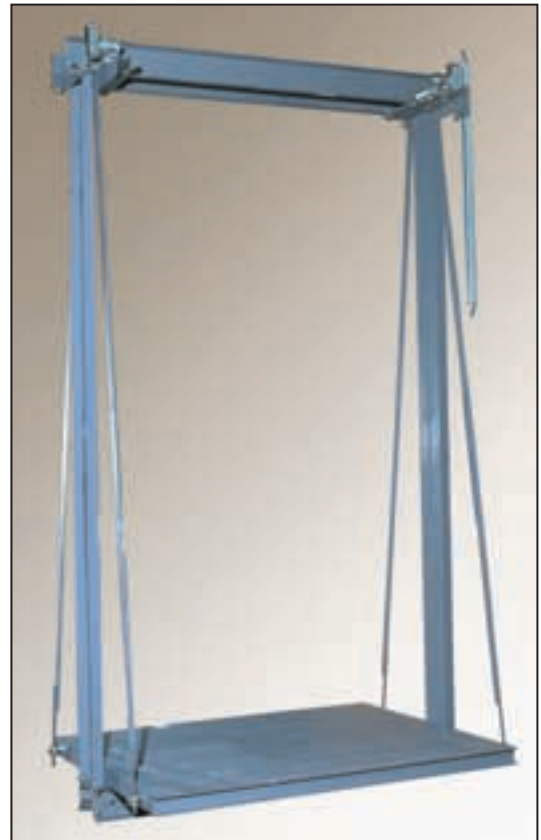

TW INLIGHT HYDRAULIC ELEVATOR PACKAGES FOR 2-LANDING INSTALLATIONS

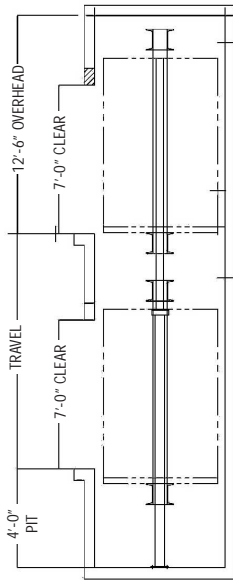

**TWO LANDINGS
FRONT OPENINGS**

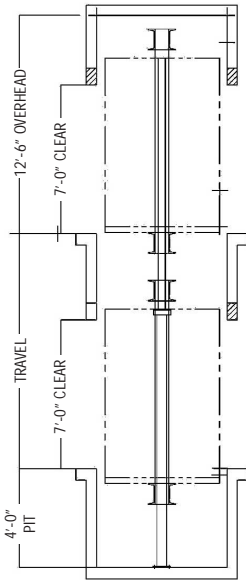

**TWO LANDINGS
FRONT & REAR OPENINGS**

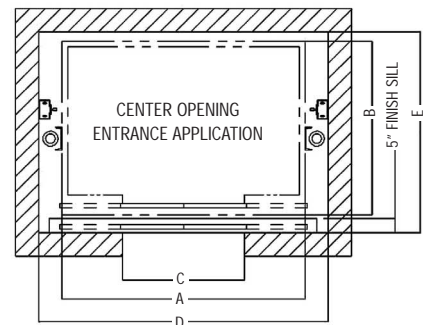
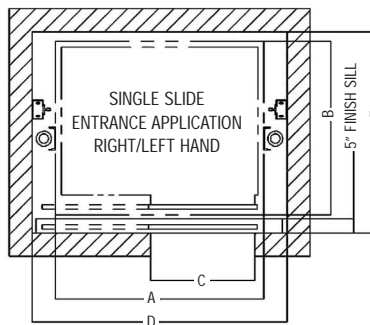
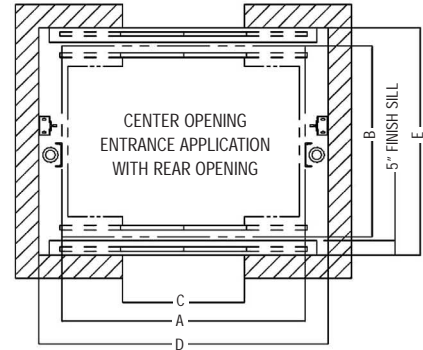
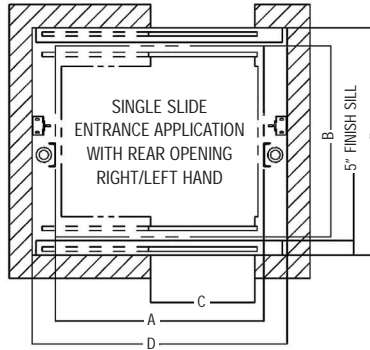

SPECIFICATIONS: TW INLIGHT SERIES GENERAL

Type	Holeless Hydraulic			
Service	Passenger			
Speed	80 FPM or 100 FPM			
Capacity	2000 lb		2500 lb	
Configuration	Front only	Front & Rear	Front only	Front & Rear
A	6' 0"	6' 0"	7' 0"	7' 0"
B	5' 0"	5' 6"	5' 0"	5' 6"
C	3' 0"	3' 0"	3' 6"	3' 6"
D	7' 4"	7' 4"	8' 4"	8' 4"
E	5' 9"	6' 6 1/2"	5' 9"	6' 6 1/2"
Clear car size W x D	5' 8" x 4' 3"	5' 8" x 4' 3"	6' 8" x 4' 3"	6' 8" x 4' 3"
Pit	4' 0"			
Overhead	12' 6"			
Machine Room	7' 0" x 5' 0" x 7' 6" Machine room may vary. Consult Leistriz engineering with questions.			
Landings Served	2			
Minimum Travel	8' 4"			
Maximum Travel	12' 6"			
Entrance Types	Single slide	Single slide	Center Opening or Single Slide	Center Opening or Single Slide

For information about Twinlight, or for complete descriptions of other Leistriz elevator systems, call us directly, or visit the Leistriz web site at www.leistrizcorp.com

Leistriz

Leistriz Corporation, 165 Chestnut Street, Allendale, NJ 07401
(201) 934-8262 • Fax: (201)934-8266 • www.leistrizcorp.com